

# Bright Green Dimmers



Bright Green Dimmers is a range of low voltage dimmer units designed to control the brightness of our LED product range.

Choose Bright Green Dimmers to save energy, adjust brightness for your conditions or to enable remote control operation.



12V or 240V



0 - 100% flickerless dimming range

## Specification

Product Code	C-DIM-SL10	C-DIM-PB10	C-DIM-PT10	C-DIM-RF10	C-DIM-VC10	C-DIM-SW10
Nominal supply voltage	9-32V DC					
Peak supply voltage range	5.5 - 40V					
Maximum current output	10A					
Continuous output power, max	120W at 12V 240W at 24V					
Peak output current	30A					
Control input impedance	10kΩ					
PWM switching frequency	1kHz	240Hz ±3%; 0%-100% Duty Cycle				

\*In addition to the control options Bright Green Control is available in high load, IP68 and extended temperature range versions.

## Dimensions

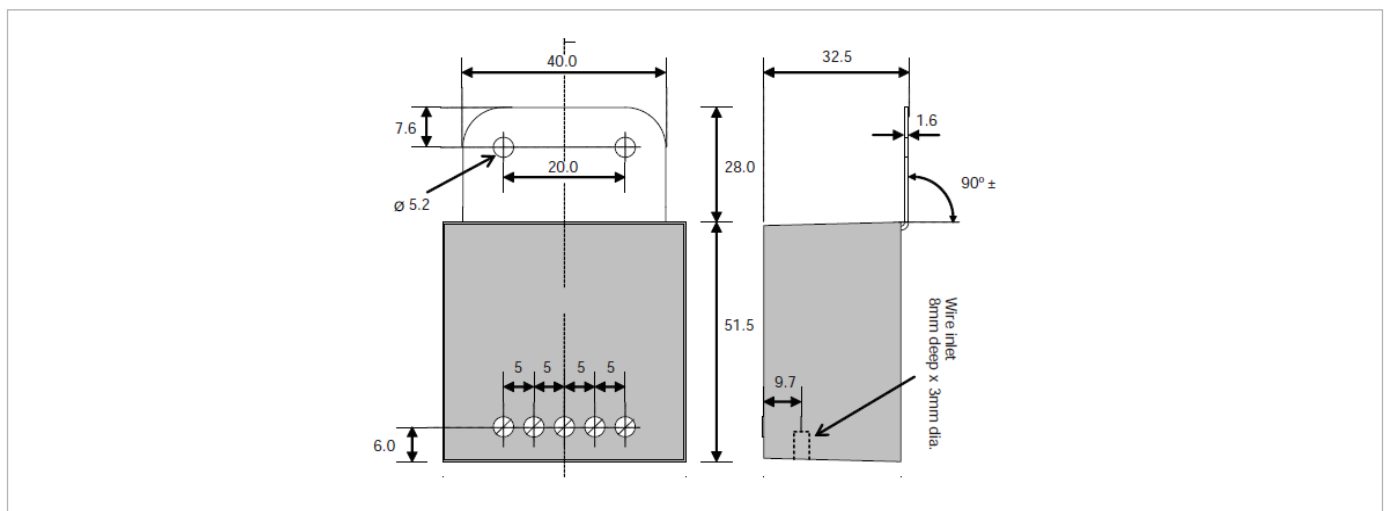

# Bright Green Dimmers

## Electrical Connection

Typical connection is a low-voltage DC supply in the range of 9 - 32V. Connection terminals are high quality rising-clamp terminal blocks capable of receiving up to 4mm<sup>2</sup> cable. The connectors are spaced at 5mm pitch. To maximise the potential of the units, cable rated at currents exceeding the load by 1.5 times should be used to connect the units, and the use of a bootlace ferrule at the dimmer terminals is recommended.

**No direct load can be put onto the master dimmer. The master can only be used to control the slaves that have the load.**

## Operation Notes

Bright Green Control operates from -5° to 70°C.

Extended temperature range options are available and operate from -40° to 70°C.

### Connection

Installation should be carried out by suitably qualified personnel.

Please see the Bright Green LED Light Panel install guide for electrical connection and handling guidelines.

## C-DIM-SL10

The C-DIM-SL10 is a slave dimmer, and must be connected to either a PB10, PT10, RF10, VC10 or SW10 to provide it with a PWM signal. An unlimited number of SL10s can be connected to the same PWM source, providing control for an unlimited amount of lighting.

Each SL10 module must have its +Supply terminal fused separately at 10A or less, and be fed from a DC supply in the range of 9 - 32V. The controlling module should have its +Supply fused at 1A.

The terminal on the SL10 marked 'no connection' is a dummy terminal and is not connected to anything inside the module.

**No direct load can be put onto the master dimmer. The master can only be used to control the slaves that have the load.**

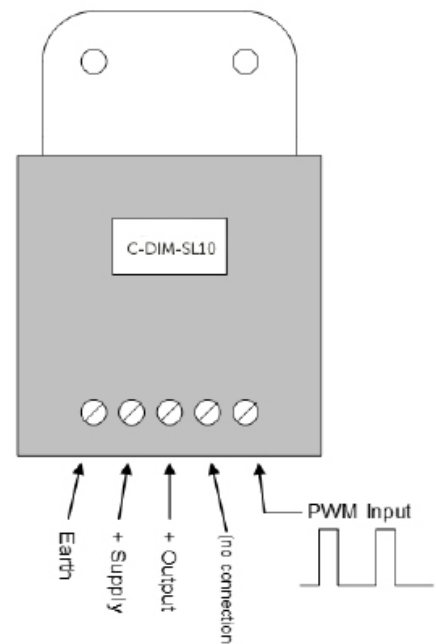

# Bright Green Dimmers

## C-DIM-PB10

C-DIM-PB10 is controlled by an integral push button.

This button controls the dimmer operation; a brief press will toggle the lamp on or off and a sustained press will cause the lamp brightness to ramp up or down for as long as the button is held, repeating until the button is released at the desired brightness level.

The Mode input should be connected at installation. Leaving the Mode input unconnected ensures full brightness at power on. Alternatively, connecting the mode input to the +supply recalls the last saved brightness at power on. The brightness ramp direction swaps between switch presses for accurate and fast adjustment.

**No direct load can be put onto the master dimmer. The master can only be used to control the slaves that have the load.**

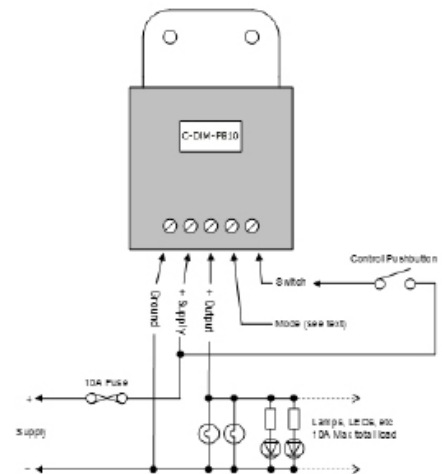

## C-DIM-PT10

C-DIM-PT10 is connected to the external potentiometer unit with 2-core cable. Turning the potentiometer shaft clockwise will increase the lamp brightness, anti-clockwise will decrease the lamp brightness.

C-DIM-PT10 features a fail-safe feature whereby in the event of an open circuit between the dimmer and the potentiometer unit, the output will default to full brightness. The dimming control can be any resistance such as a thermistor – for temperature controlled dimming, or an LDR – for light controlled dimming.  $0\Omega$  = fully off,  $10k\Omega$  = full brightness.

**No direct load can be put onto the master dimmer. The master can only be used to control the slaves that have the load.**

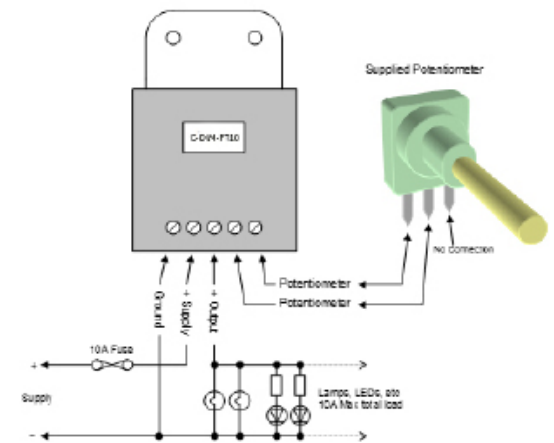

## C-DIM-RF10

C-DIM-RF10 is a fully self-contained radio controlled dimmer modules designed to remotely control the brightness of low-voltage incandescent (filament), halogen or LED lamps rated up to 10A. The units are remote controlled with one or more keyfob-style radio transmitters, allowing the lamp brightness to be increased or decreased from up to 150m away. No direct line of sight is needed unlike infra-red.

**No direct load can be put onto the master dimmer. The master can only be used to control the slaves that have the load.**

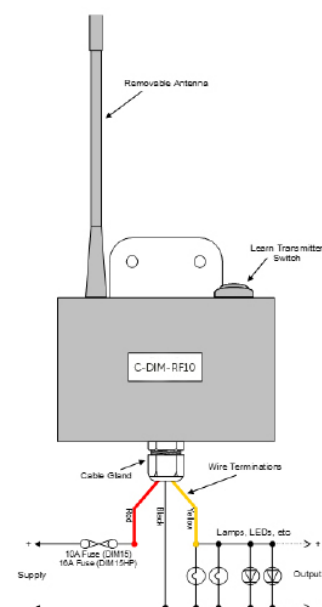

# Bright Green Dimmers

## C-DIM-VC10

The control input is designed to accept an analogue 0-10V control signal from a PLC, lighting controller, Crestron™ controller, or similar. As the input signal is varied between 0 and 10V the brightness changes synchronously. An input of less than 0.2V turns the lamp fully off and more than 9.8V turns the lamp fully on.

The two earth connections on the unit are internally tied together and only one of them can be connected if desired. The control input is protected against over-voltage, although it should never exceed the unit's supply voltage. The control voltage input and the dimmer supply voltage are not electrically isolated from each other.

**No direct load can be put onto the master dimmer. The master can only be used to control the slaves that have the load.**

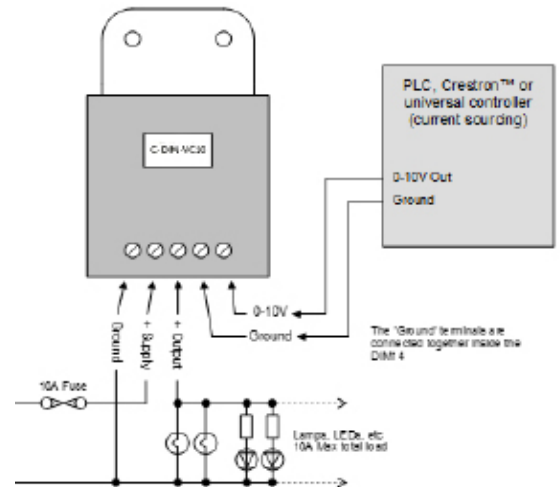

## C-DIM-SW10

The 'Brighter' and 'Dimmer' inputs should be switched to positive through a suitable rocker switch or push buttons (not supplied) – a centre-off momentary rocker switch is shown below-left, and push buttons are shown below-right. A brief press of the switch will increase or decrease the brightness a small amount. If the switch is pressed continuously, the brightness will increase or decrease for as long as the switch is held, until either the fully-on or fully-off state is reached. The 'switch' can be any kind of switch, including relay contacts, but it must be switched to the positive supply voltage.

The C-DIM-SW10 has a built-in function to save the current brightness setting. The brightness level remains in memory when power is removed and is restored when power is re-applied.

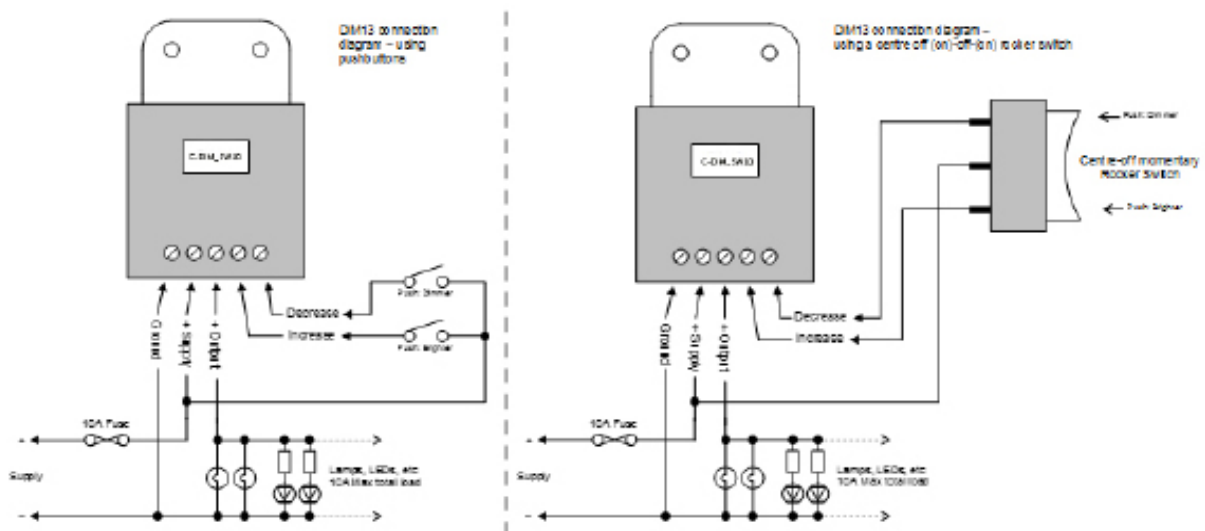

**No direct load can be put onto the master dimmer. The master can only be used to control the slaves that have the load.**