

Bright Green LED Snap Frame

LED Snap Frames are ideal for retail displays; improving illumination, reducing costs and increasing efficiency compared with traditional boxes lit with fluorescent tubes.

We specialise in delivering volume light box roll-outs to retail environments. We work with you on every aspect of the design process, to make sure that we deliver a system that meets your specification exactly.

Prototyping service available



Strict bin control for consistent colour temperature

custom sizes

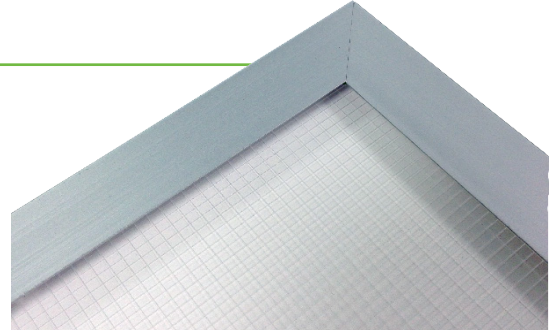

Profile	Anodised extruded aluminium snap frame
Dimensions	Made in custom sizes to meet your requirements.. Max. 2400mm x 2000mm. Tolerance \pm 1mm
Depth	Single sided: 20 or 39mm Double sided 46mm
Colour	Silver anodised as standard, optional powder coating
Graphic	Backlit display prints i.e Duratrans
Lighting	LED Light Panel

Dimensions

Single sided - 20mm

Print size - outer frame dimension minus 17mm

Visible image area - outer frame dimension minus 44mm

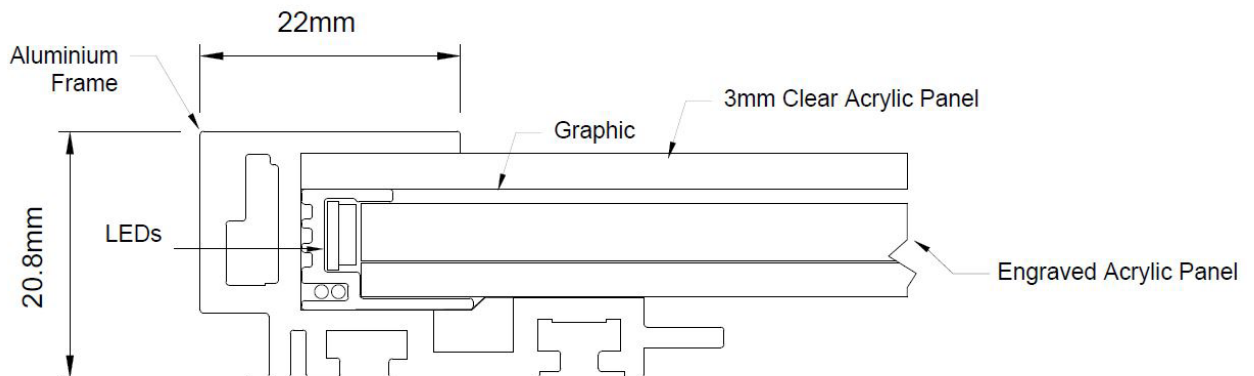

Tel +44 (0) 1932 355221 Email info@brightgreentechnology.com
Find out more at www.brightgreentechnology.com

Bright Green LED Snap Frame

Single sided - 39mm

Print size - outer frame dimension minus 20mm

Visible image area - outer frame dimension minus 68mm

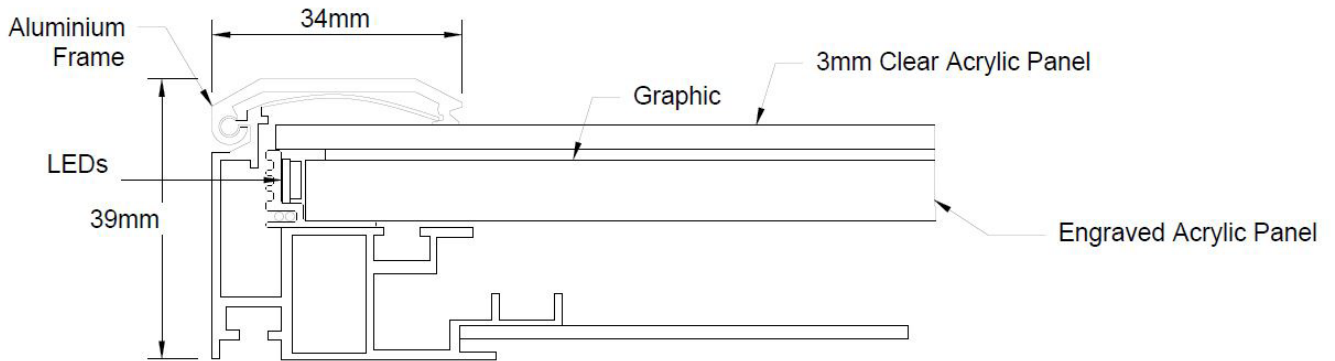

Double sided - 46mm

Print size - outer frame dimension minus 17mm

Visible image area - outer frame dimension minus 44mm

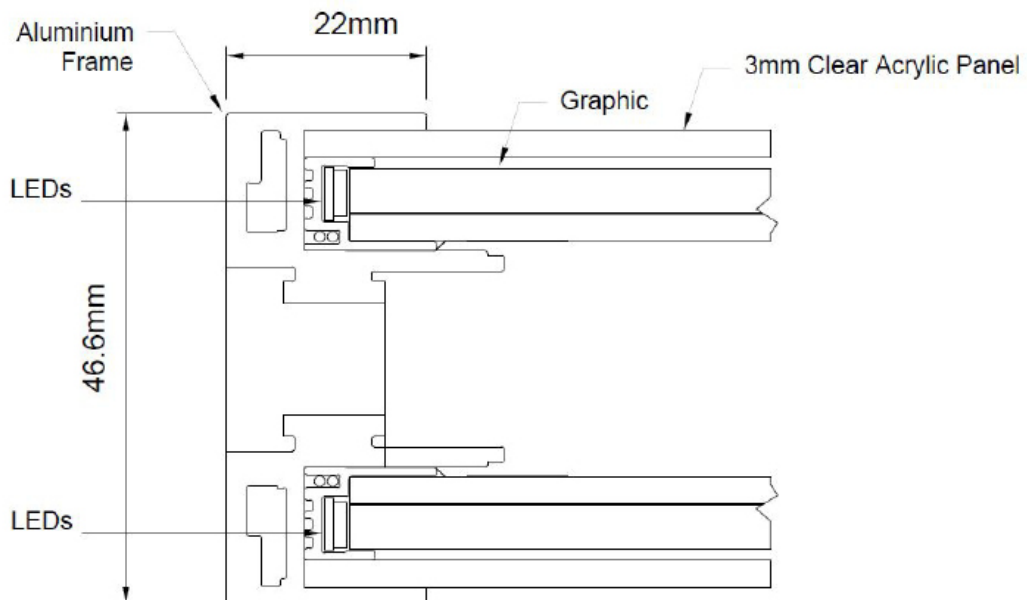

Connection

Installation should be carried out by suitably qualified personnel.

Optional PAT testing available to make the whole unit plug and play.



Tel +44 (0) 1932 355221 Email info@brightgreentechnology.com
Find out more at www.brightgreentechnology.com

© 2016 Bright Green Technology Limited

bright green.
technology 